

Student Handout #3—Sewing-Tool Caddy Pattern

SEW TEACH ME™ Lesson Three

Making a Sewing-Tool Caddy

Sewing Tool Caddy

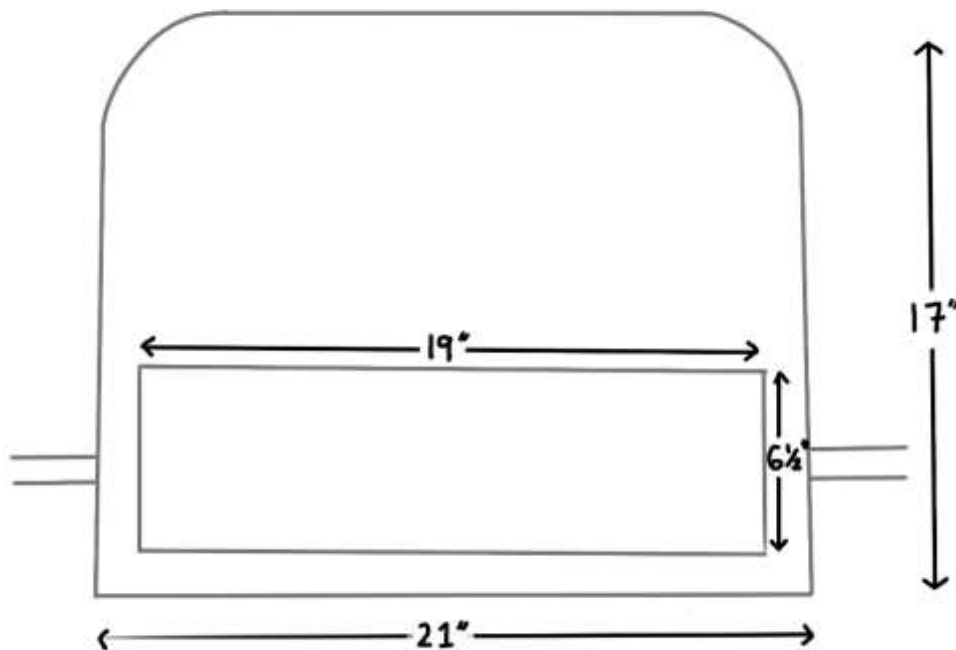

Techniques for the Sewing-Tool Caddy

- Using fusible interfacing
- Clipping corners
- Sewing an accurate seam allowance
- Being creative with corners (rounded)
- Clipping rounded corners
- Using a point turner
- Top stitching
- Using ribbon for ties

Supplies

- Three fat quarters, two that are identical and one coordinating fat quarter

- 6" x 19" piece of fusible interfacing
- Coordinating thread
- Seam ripper
- Pins
- Point turner
- Iron
- Scissors
- Seam guide
- Paper plate to use as a guide to round the corners

Cutting Directions

1. Cut and square up the two identical fat quarters to measure 17 ½" x 21 ½".
2. Cut the contrasting fat quarter into two pieces measuring 6 ½" x 19 ½". This is the pocket.
3. Cut one 6" x 19" piece of fusible interfacing.

Sewing Directions—Pocket

1. Fuse the interfacing to the **WRONG** side of one of the pocket pieces. Try to center the interfacing.
2. Put both pieces of the pocket right sides together.
3. Pin, leaving an 8" opening at the bottom.
4. At each end of the opening, use two pins to mark the opening.
5. Using a fabric marker, mark ½" from the corner on both sides of each corner. You will want to shorten your stitch length at the corners to reinforce them.
6. Using a seam guide, mark for a ½" seam allowance.
7. Sew the ½" seam allowance, backstitching at the beginning and end of the 8" opening.
8. Trim the corners to reduce bulk. Be careful not to clip into the stitching.
9. Turn right side out.
10. Using the point turner, gently push out each corner.
11. Press the pocket flat, turning the 8" opening under ½".
12. Topstitch the top of the pocket about ¼" from the edge to reinforce the pocket (the side without the opening).

Sewing Directions—Attaching the Pocket

1. If focus fabric is directional, decide how you want it on the inside and the outside of the caddy.
2. Draw a line 1¼" above the bottom of the inside focus fabric. Place the bottom of the pocket on the marked line.
3. Center the pocket from each edge and place on the line.
4. Pin all three sides, (but not the top of the pocket) to the focus fabric, using more pins than fewer pins.
5. Sew the pocket to the focus fabric, backstitching at the beginning and ending to reinforce the pocket.
6. Again, shorten your stitch length a little before and after each corner.

Sewing Directions—Making the Caddy Body

1. Place the focus fabric pieces wrong sides together to confirm they are the same size.
2. If they are not the same size, trim them up.
3. Find a paper plate, a plate or a bowl and use it to mark the top of both pieces to round the corners.
4. Cut out the rounded corners.
5. Put the focus fabrics **RIGHT SIDES** together and pin leaving a 5" opening on the right side near the pocket. (You will be putting your ties in there after you sew it.)
6. Mark both sides of the opening so that you can backstitch at the beginning and end of it.
7. Sew with a $\frac{1}{2}$ " seam allowance all the way around.
8. Clip the curved corners.
9. Turn right sides out, using the point turner in the corners.
10. Press it flat, including pressing under $\frac{1}{2}$ " of both fabrics at the opening.

Sewing Directions—Adding the Ribbon Ties and Finishing the Caddy

1. Fold the ribbon in half. Insert the folded part into the opening and pin.
2. Topstitch completely around the caddy.
3. You can make individual decisions on how far apart your stitching lines are on the pocket depending on the use of the pocket. You can also consider making some of the slots shorter by sewing a line 1" above the bottom of the pocket.

This completes the third project.

- Collect your students' nametags.
- Have your students clean up their area.